

**GEOMETRIC
ABSTRACTIONS**

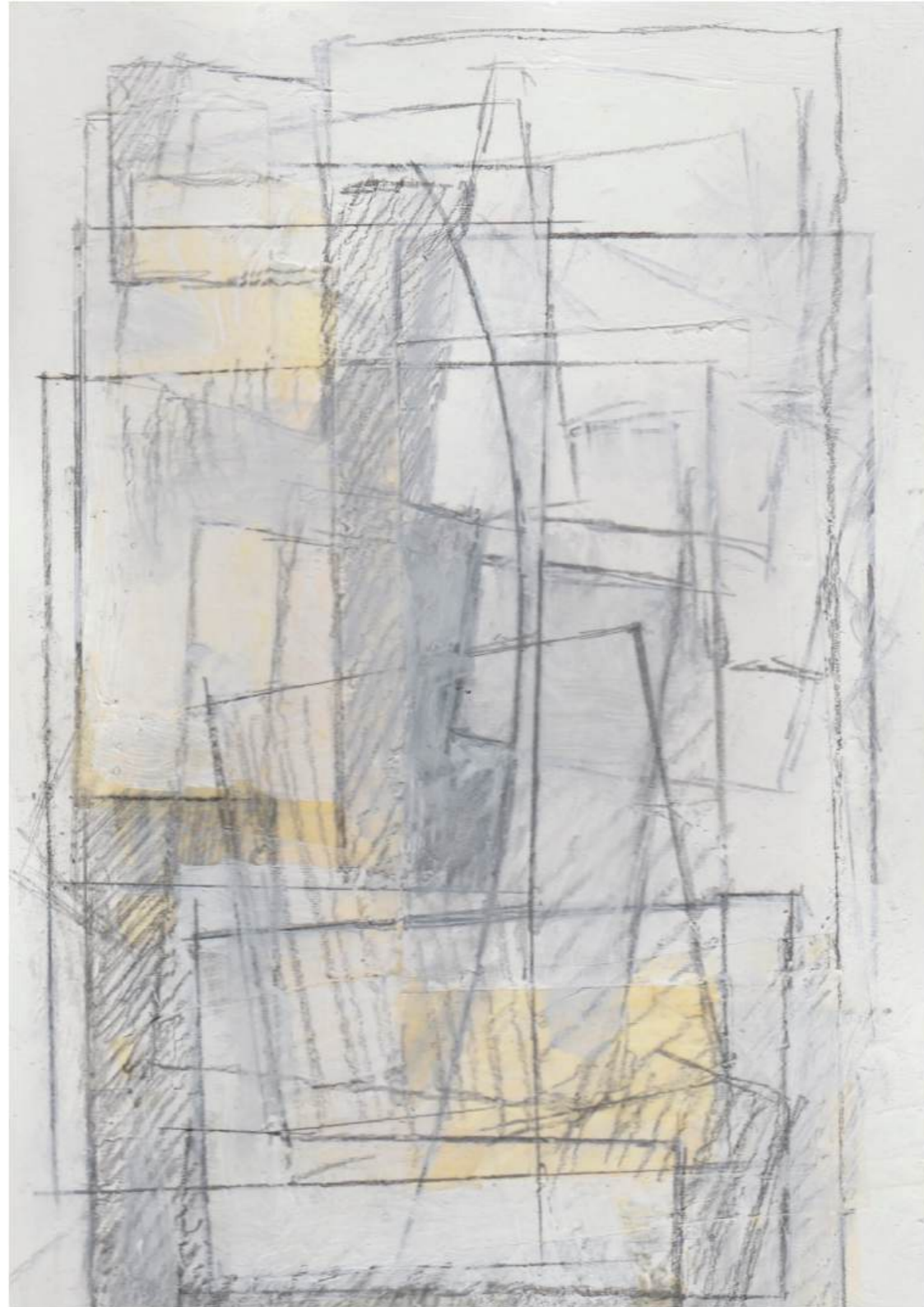

MAX OSTROVERHY

**LONDON
2024**



LONDON CITY

My abstract geometrical compositions serve as vessels, reflecting my visual understanding of the world around me. I perceive the environment as a collection of fundamental shapes -squares, prisms, and spheres -that form the essence of everything, from people to buildings. The organic and the industrial coexist within this framework.

Whether observing mountain ranges or cityscapes, the underlying pattern remains constant: materials evolve over time, weathered and aged by natural forces, leaving humanity as mere witnesses. Currently, I find myself surrounded by skyscrapers -the towering structures of London's financial district and the timeless silhouette of St. Paul's Cathedral. Their transparency, structural logic, and drafts breathe life into their forms, creating a sense of vitality amidst the austere.

My goal is to translate these atmospheric impressions of the city -its modern built environment and the seemingly soulless yet grand architecture -into transient paintings. These works aim to bridge the viewer's familiarity with stark urbanity and a deeply personal sense of aesthetic balance, revealing an inner universality within the austere.

Max Ostroverhy
London, 2024

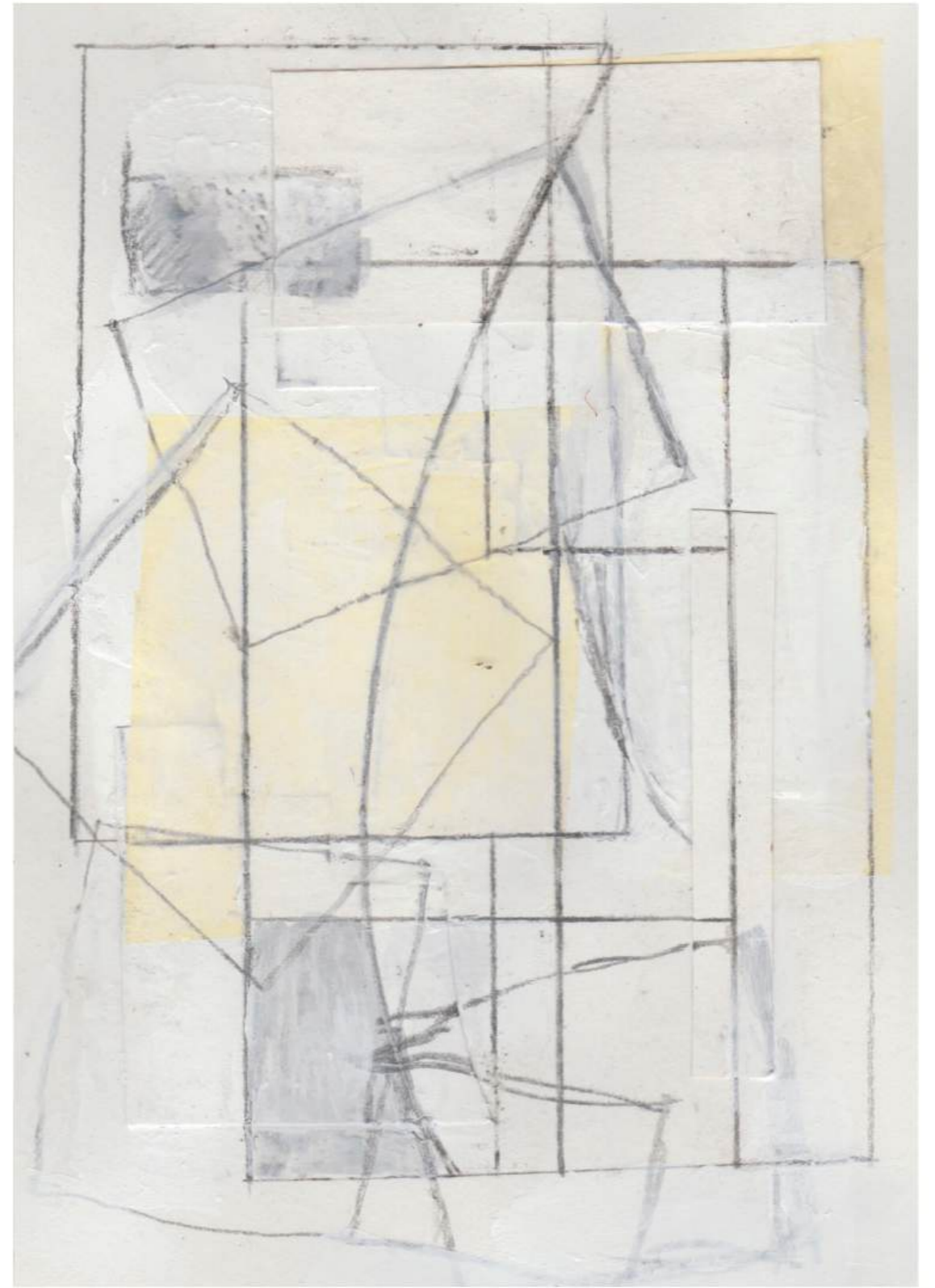
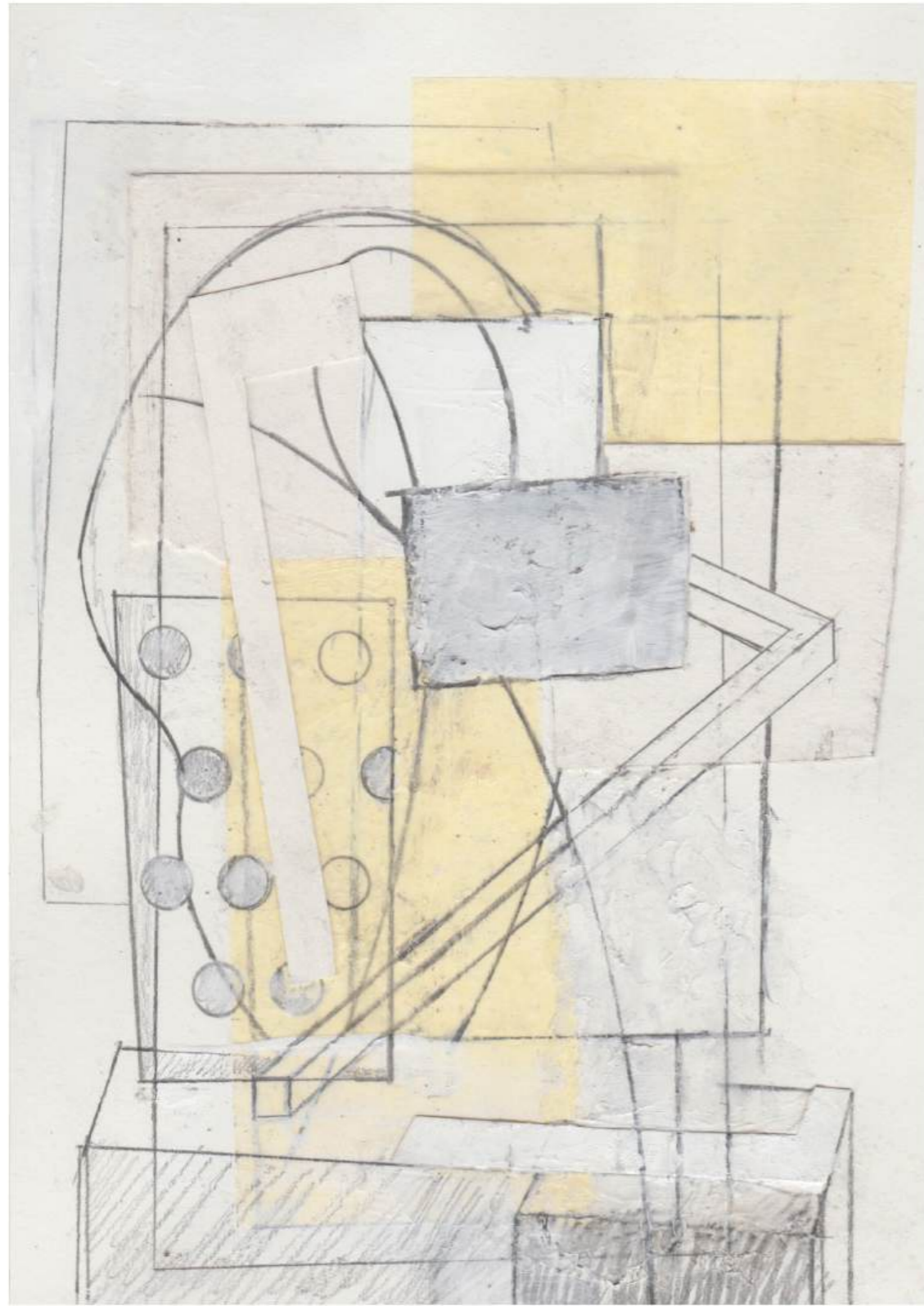

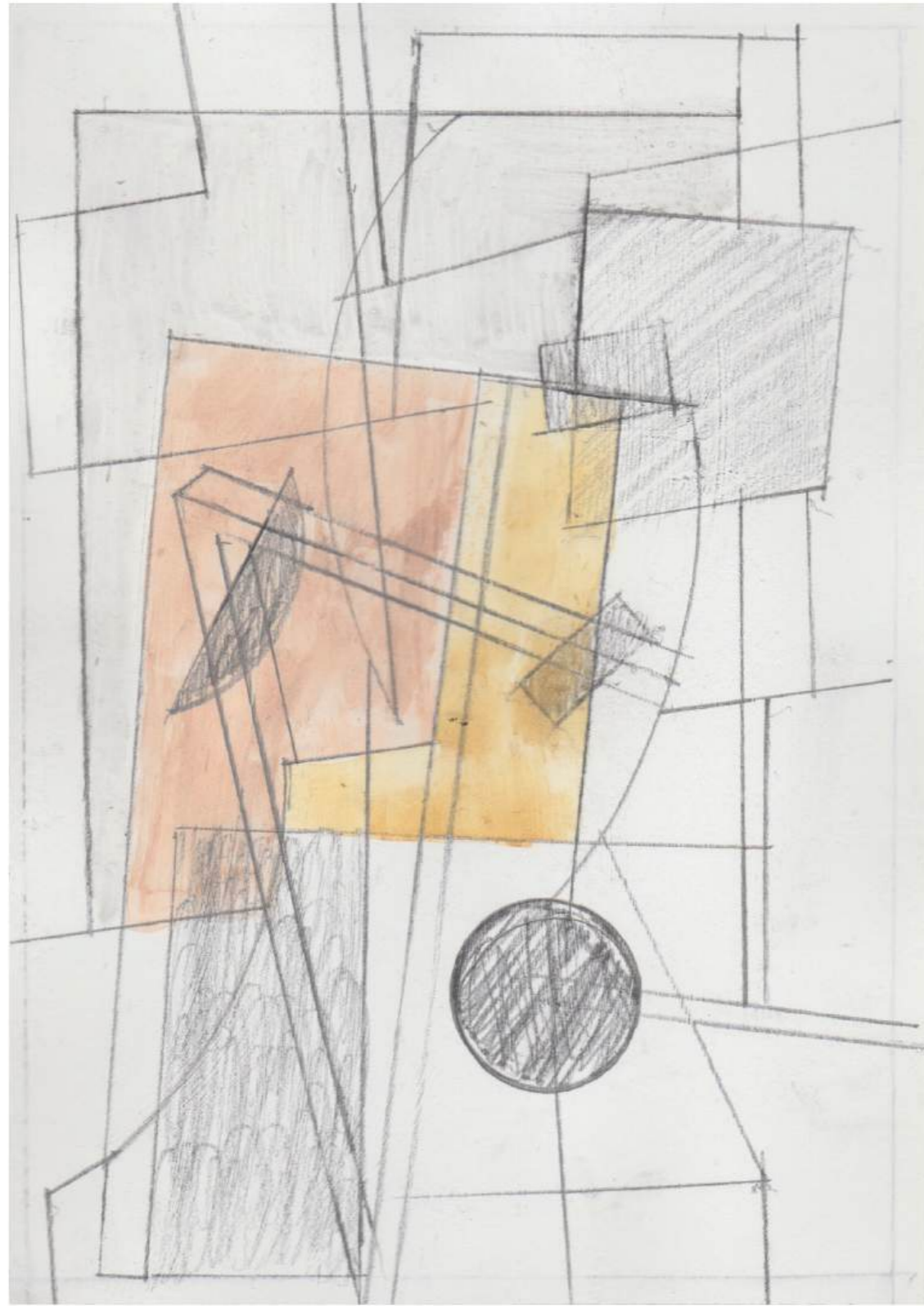

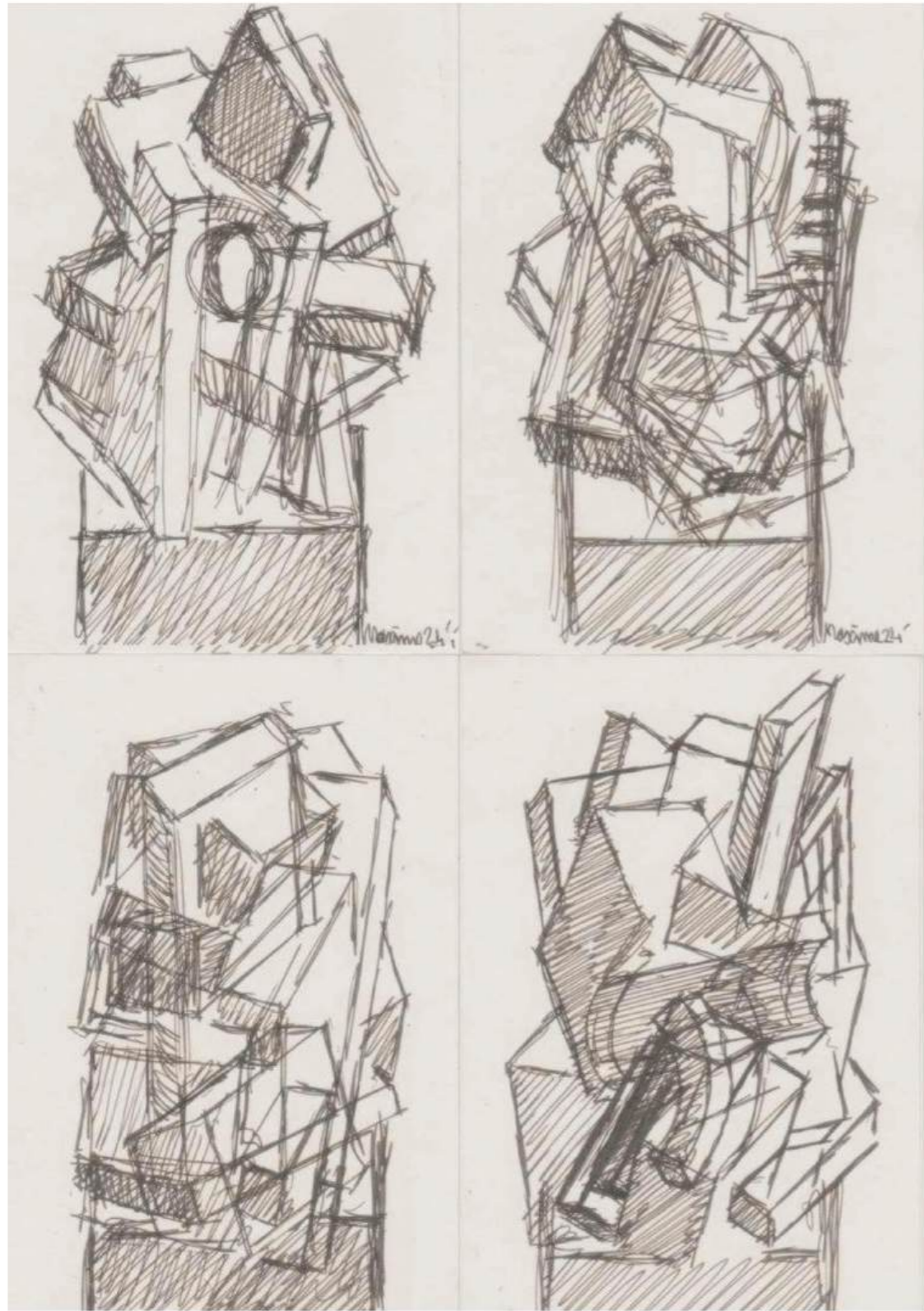

SCULPTURE PROJECTS
30CM / 21 CM, INK ON PAPER
LONDON, 2024

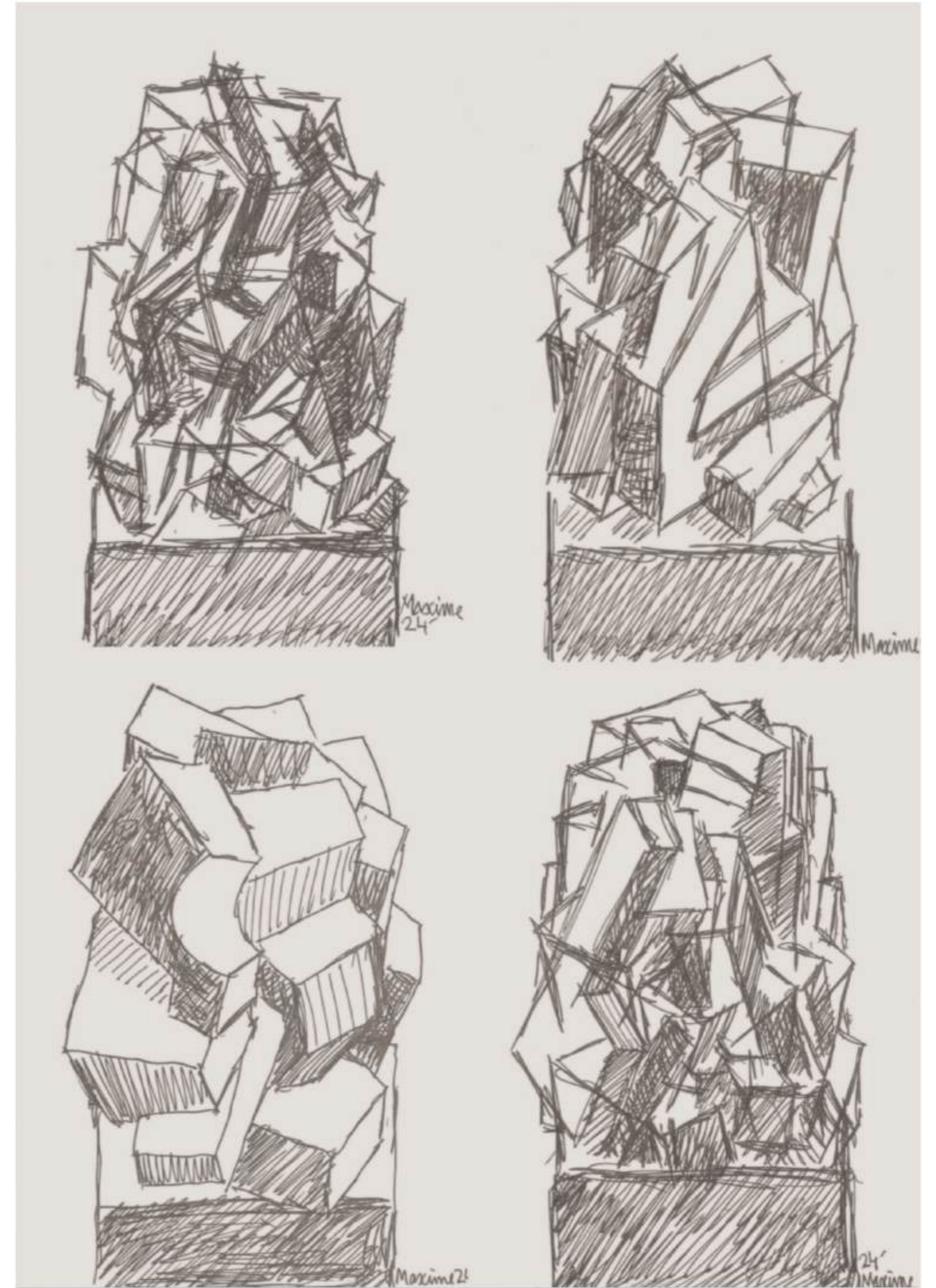

SCULPTURE PROJECTS
30CM / 21 CM, INK ON PAPER
LONDON, 2024

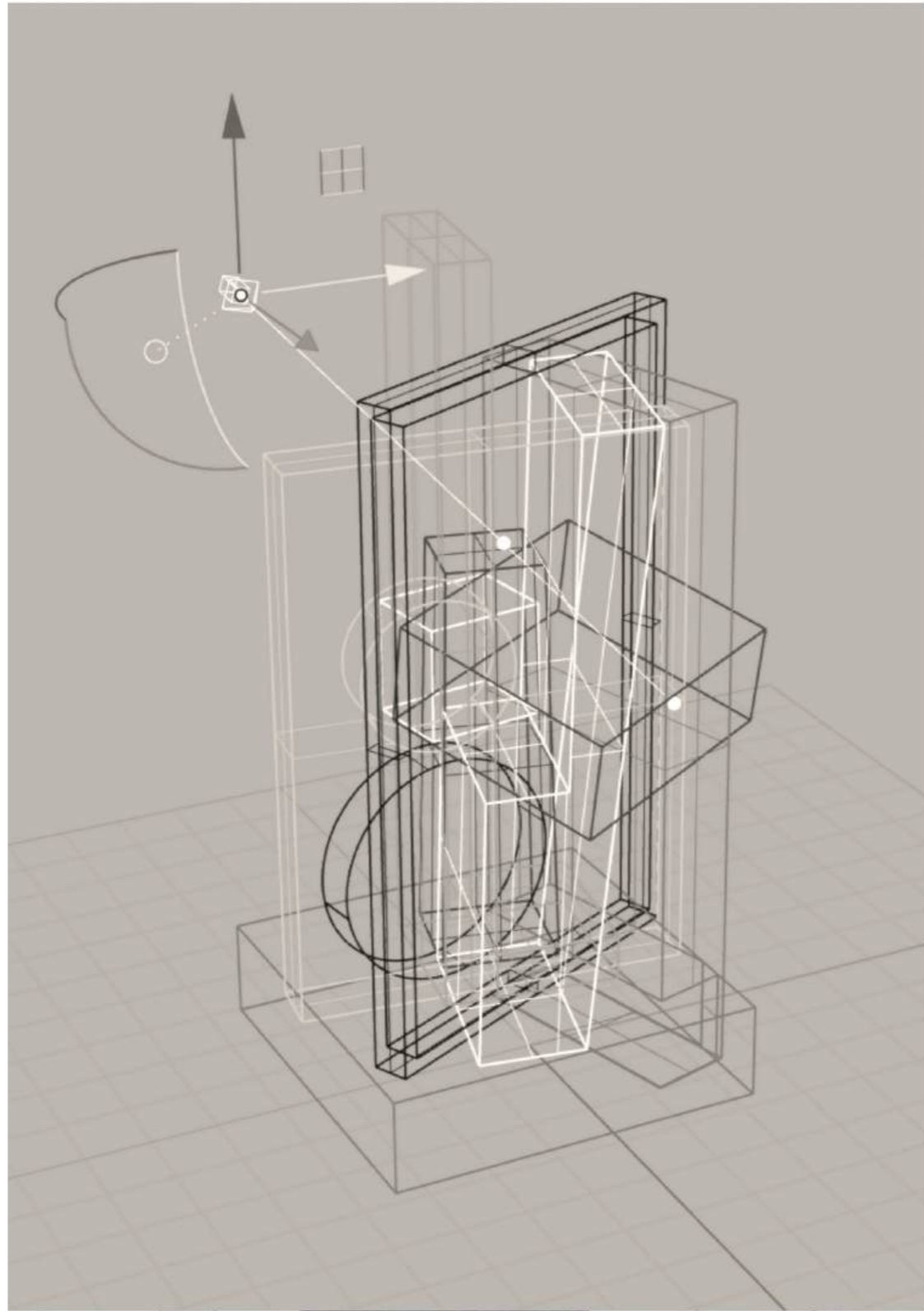

PROJECT
FOR COMPOSITE SCULPTURE
COMPUTER SCREEN GRAPHICS
LONDON, 2024

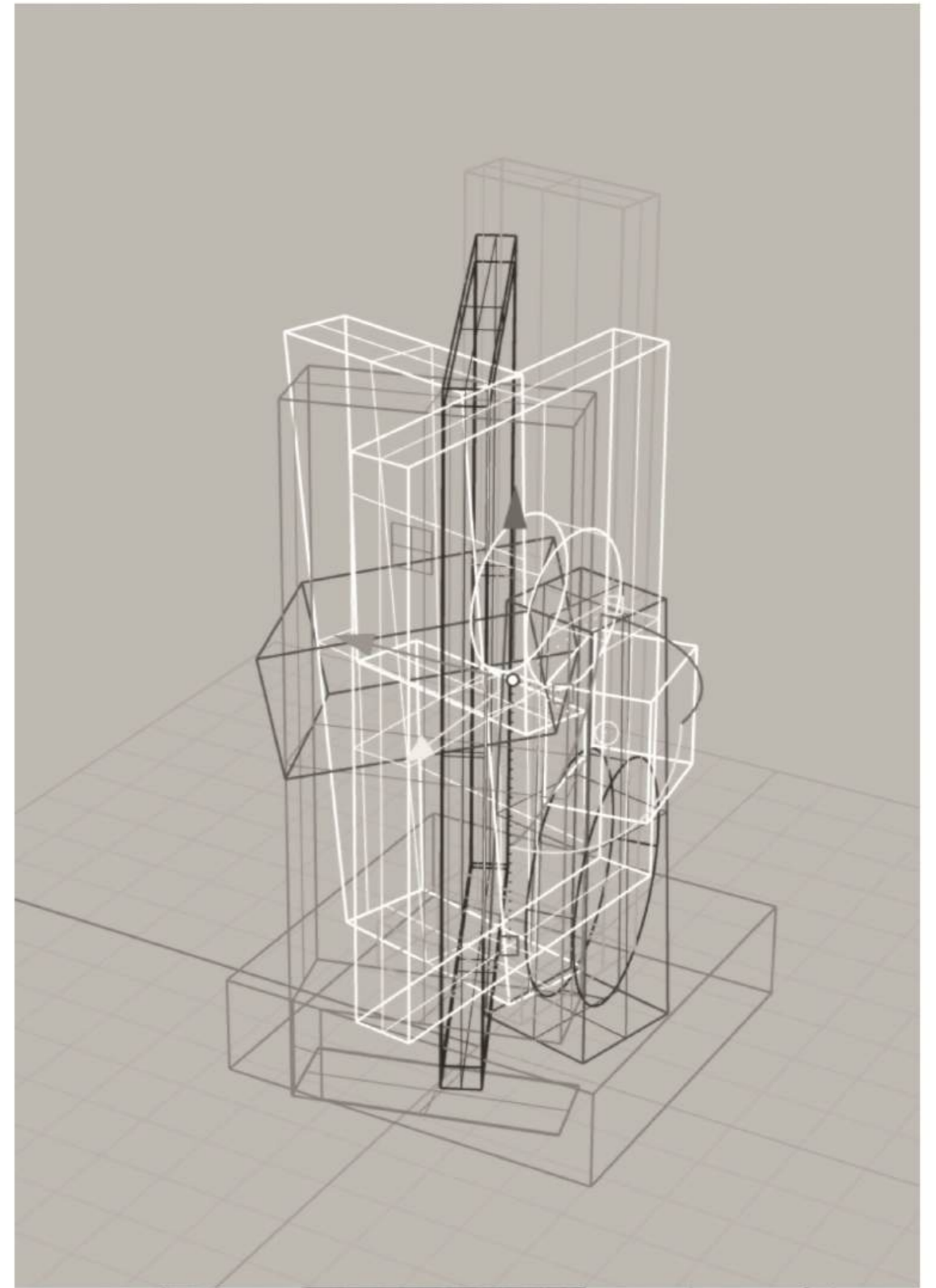

PROJECT
FOR COMPOSITE SCULPTURE
COMPUTER SCREEN GRAPHICS
LONDON, 2024

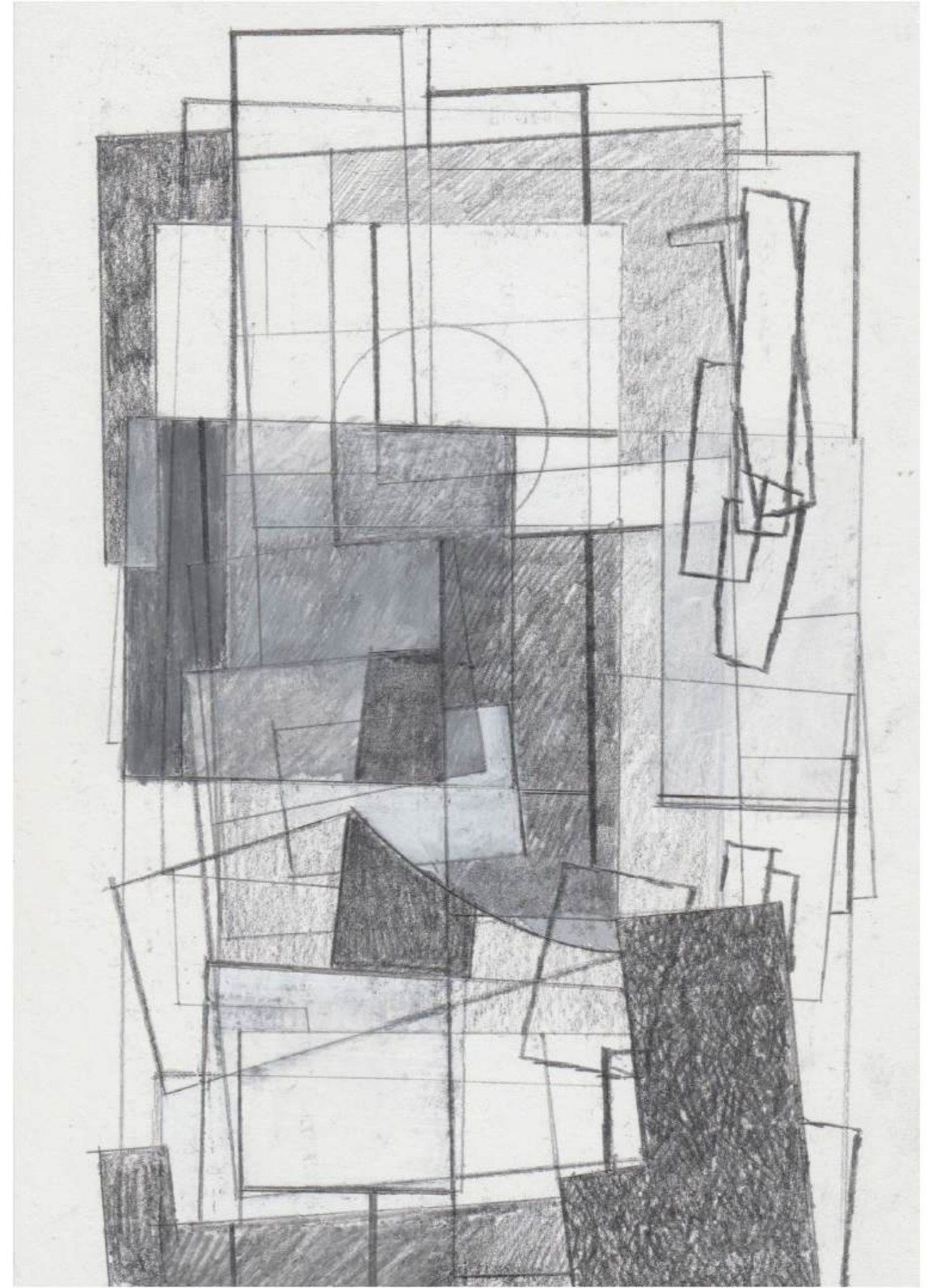
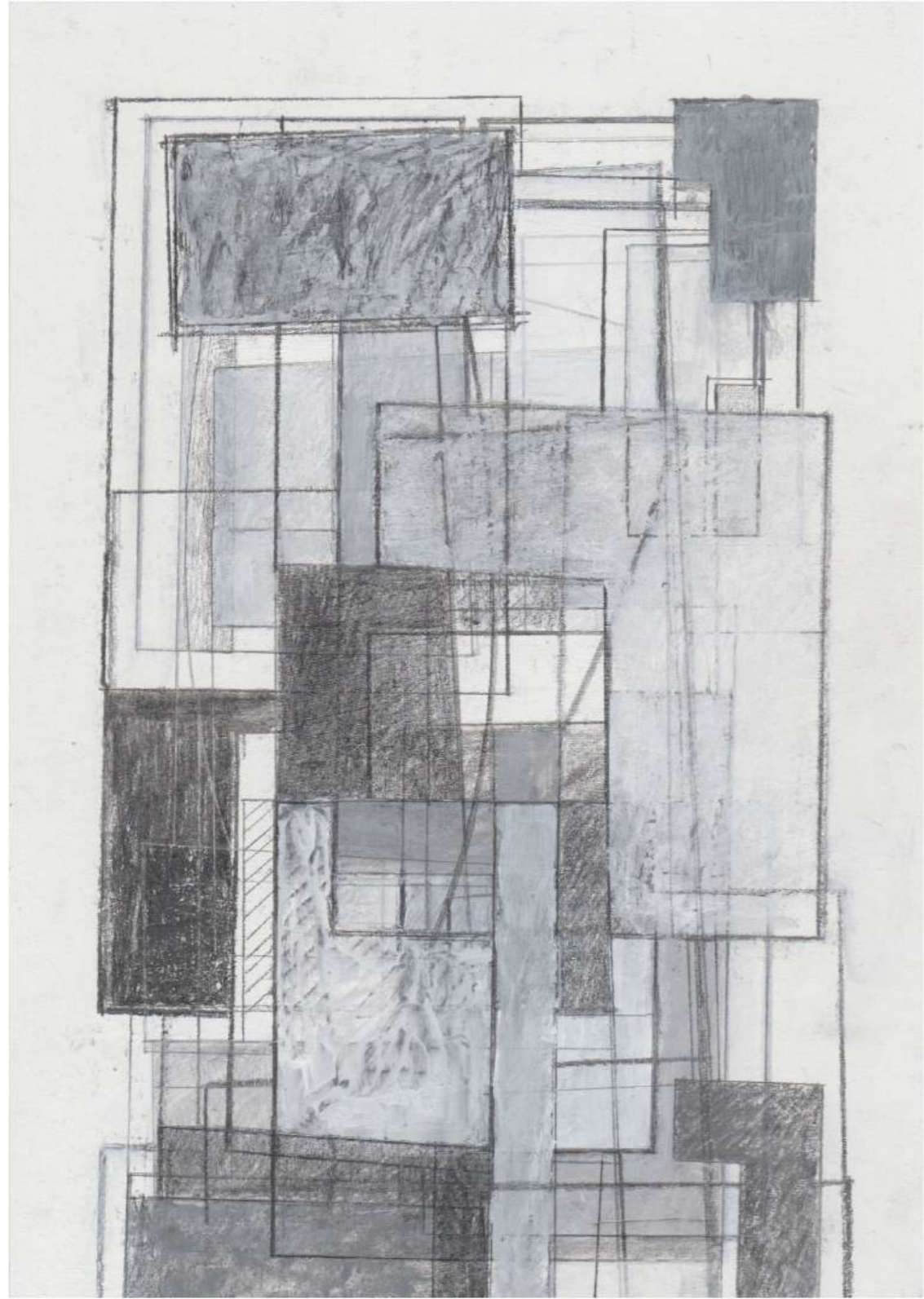

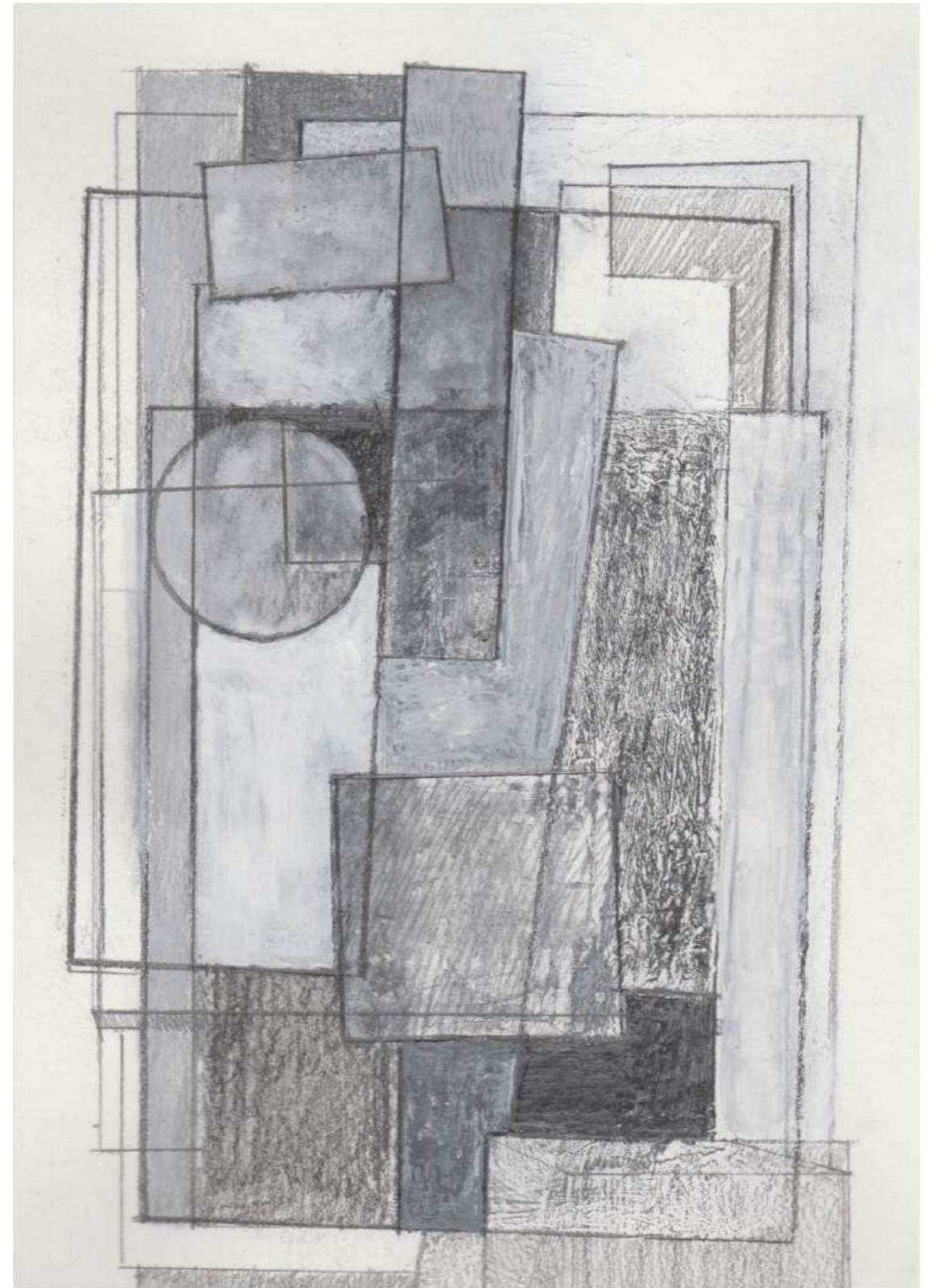
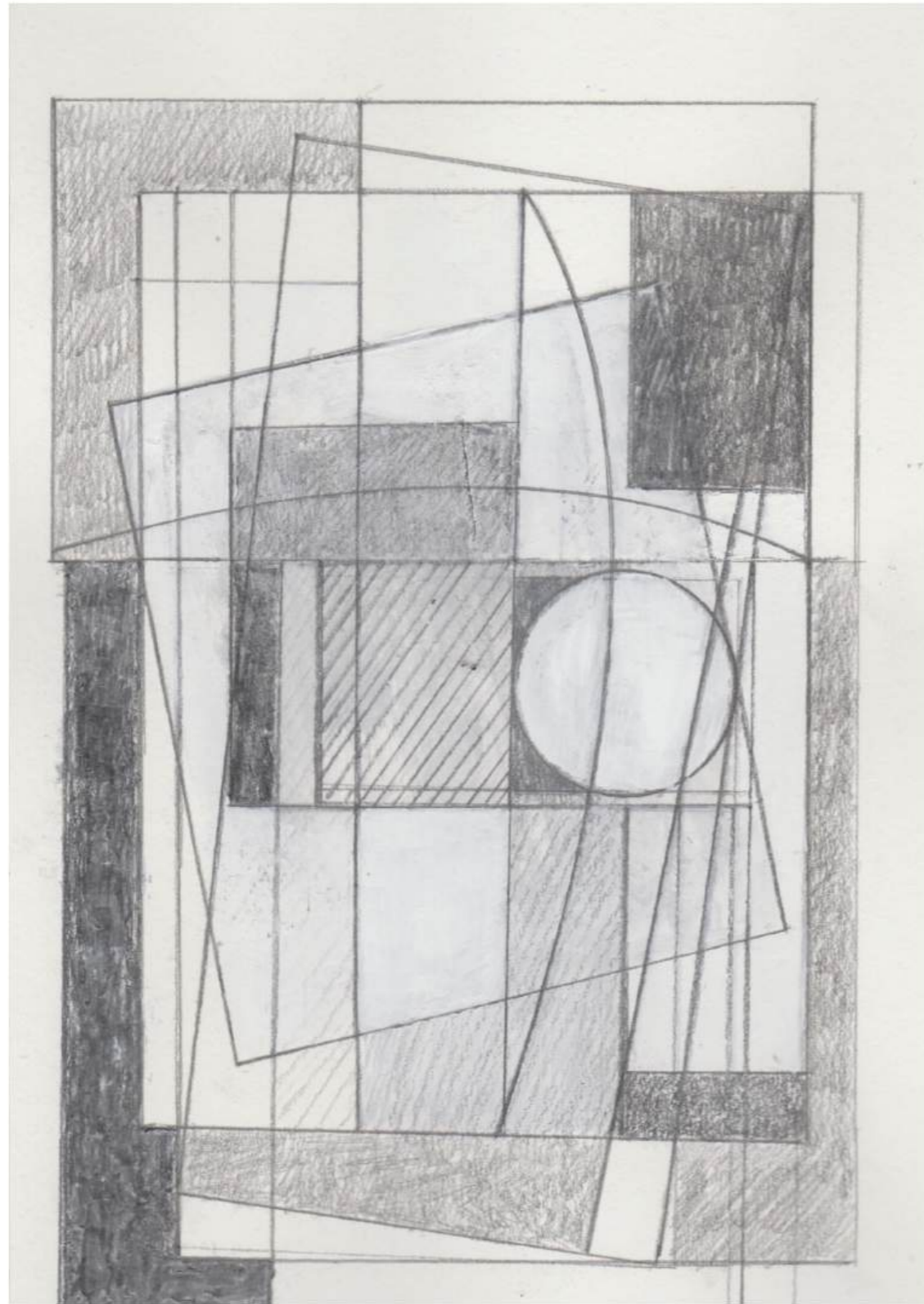

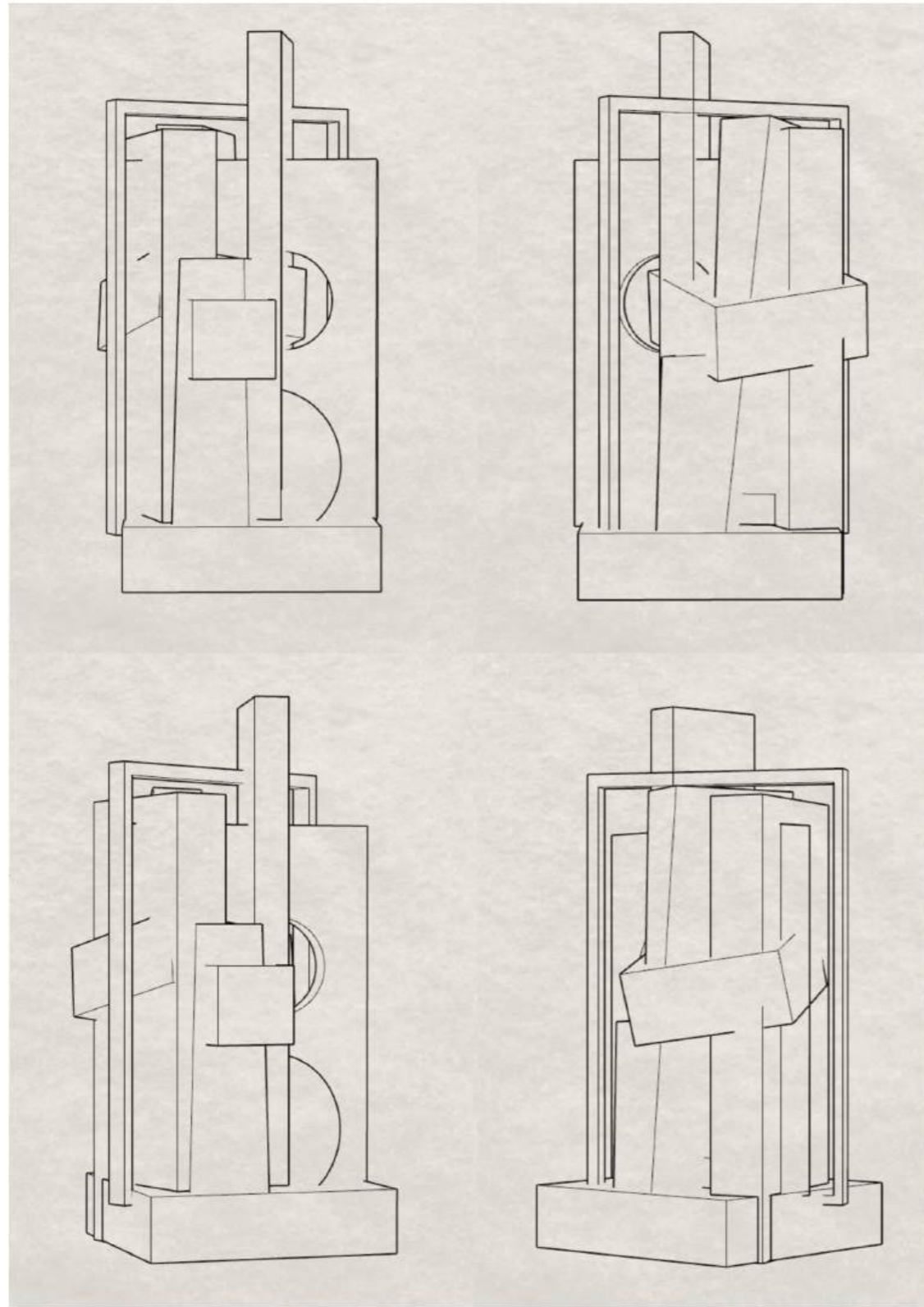

PROJECT
FOR COMPOSITE SCULPTURE
COMPUTER SCREEN GRAPHICS
LONDON, 2024

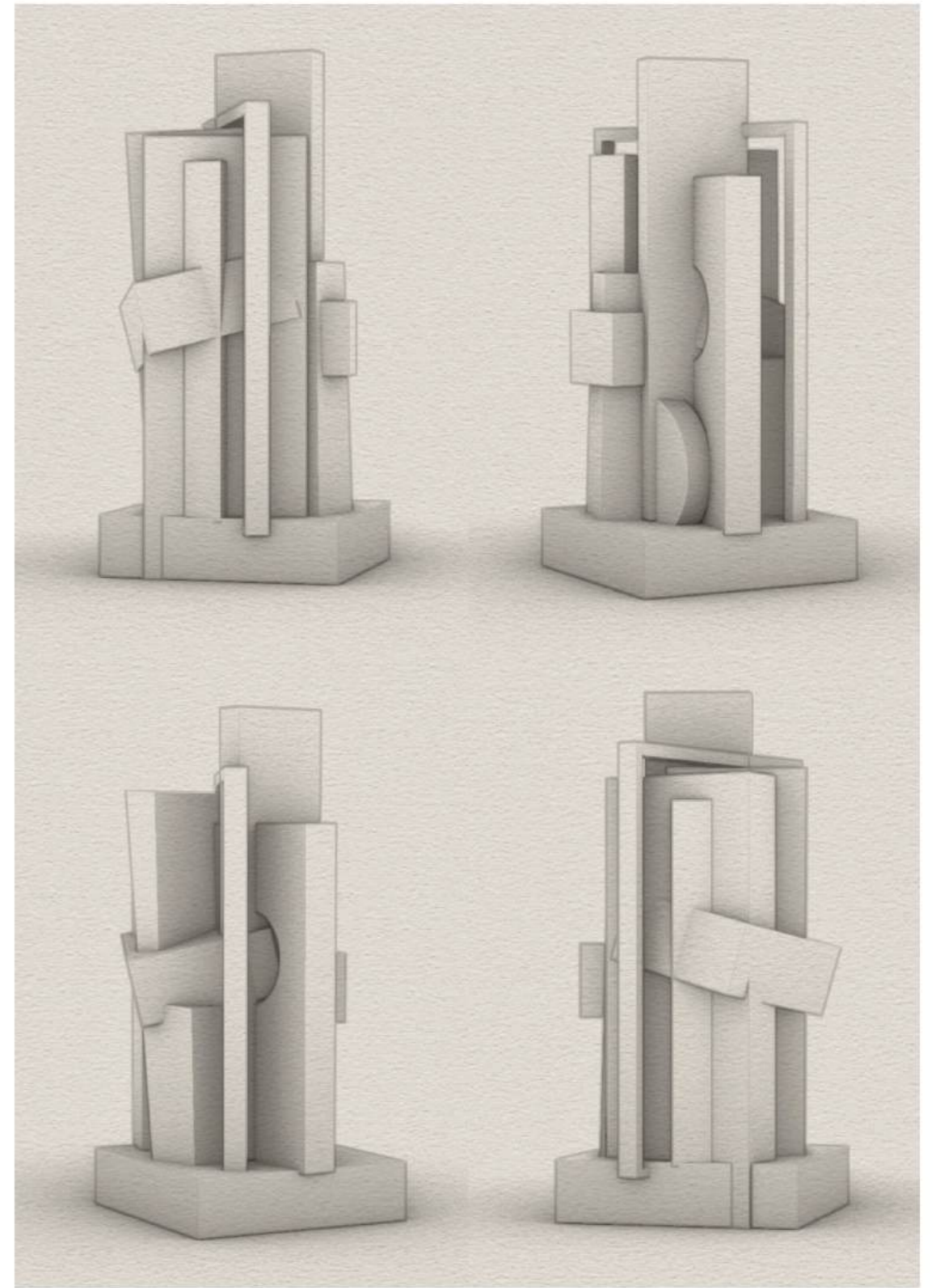

PROJECT
FOR COMPOSITE SCULPTURE
COMPUTER SCREEN GRAPHICS
LONDON, 2024





"ISOMETRIC ABSTRACTION N5"
28CM /21 CM, MIXED MEDIA ON PAPER
LONDON, 2024



"ISOMETRIC ABSTRACTION N7"
28CM /21 CM, MIXED MEDIA ON PAPER
LONDON, 2024

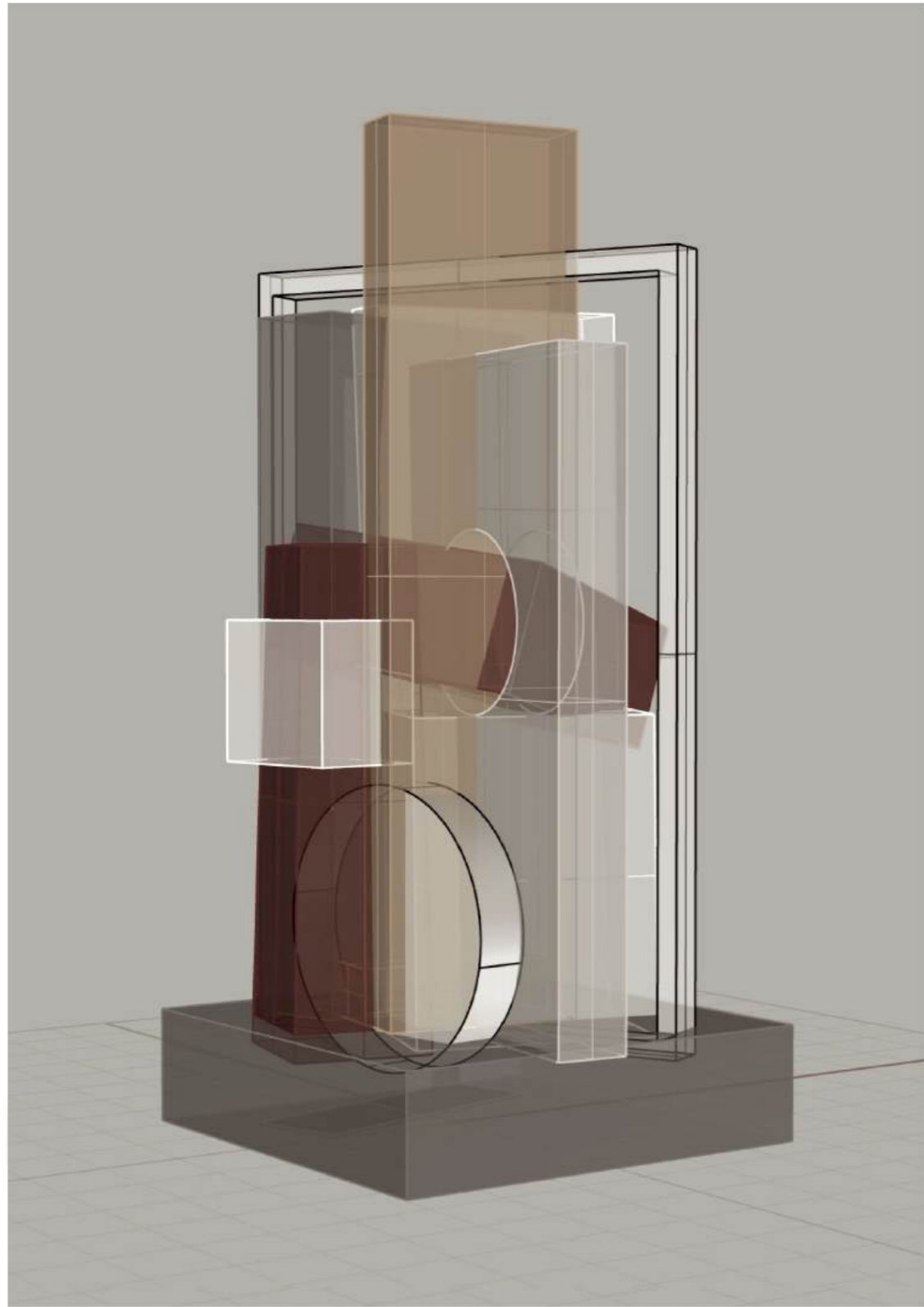

PROJECT
FOR COMPOSITE SCULPTURE
COMPUTER SCREEN GRAPHICS
LONDON, 2024

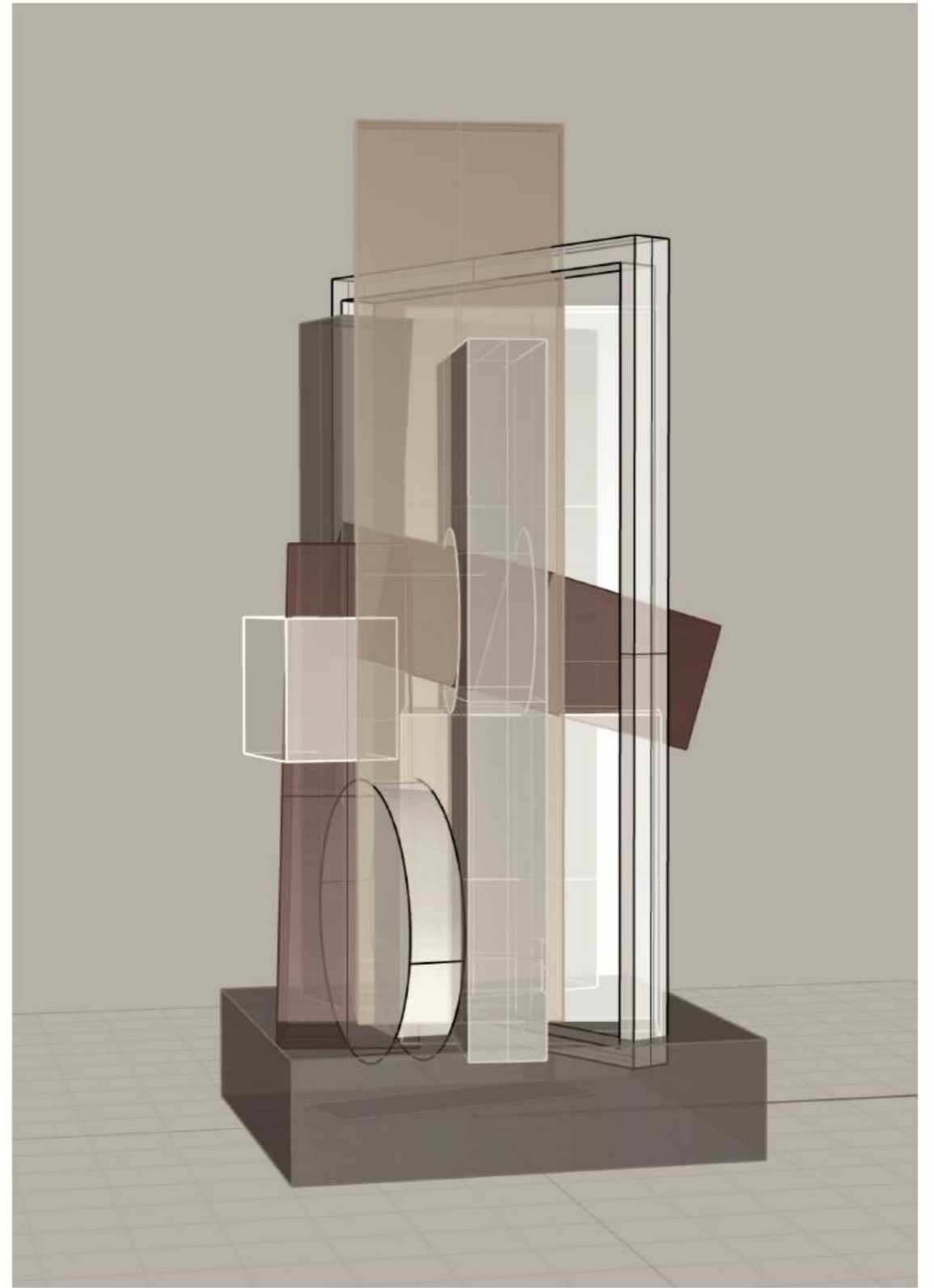

PROJECT
FOR COMPOSITE SCULPTURE
COMPUTER SCREEN GRAPHICS
LONDON, 2024

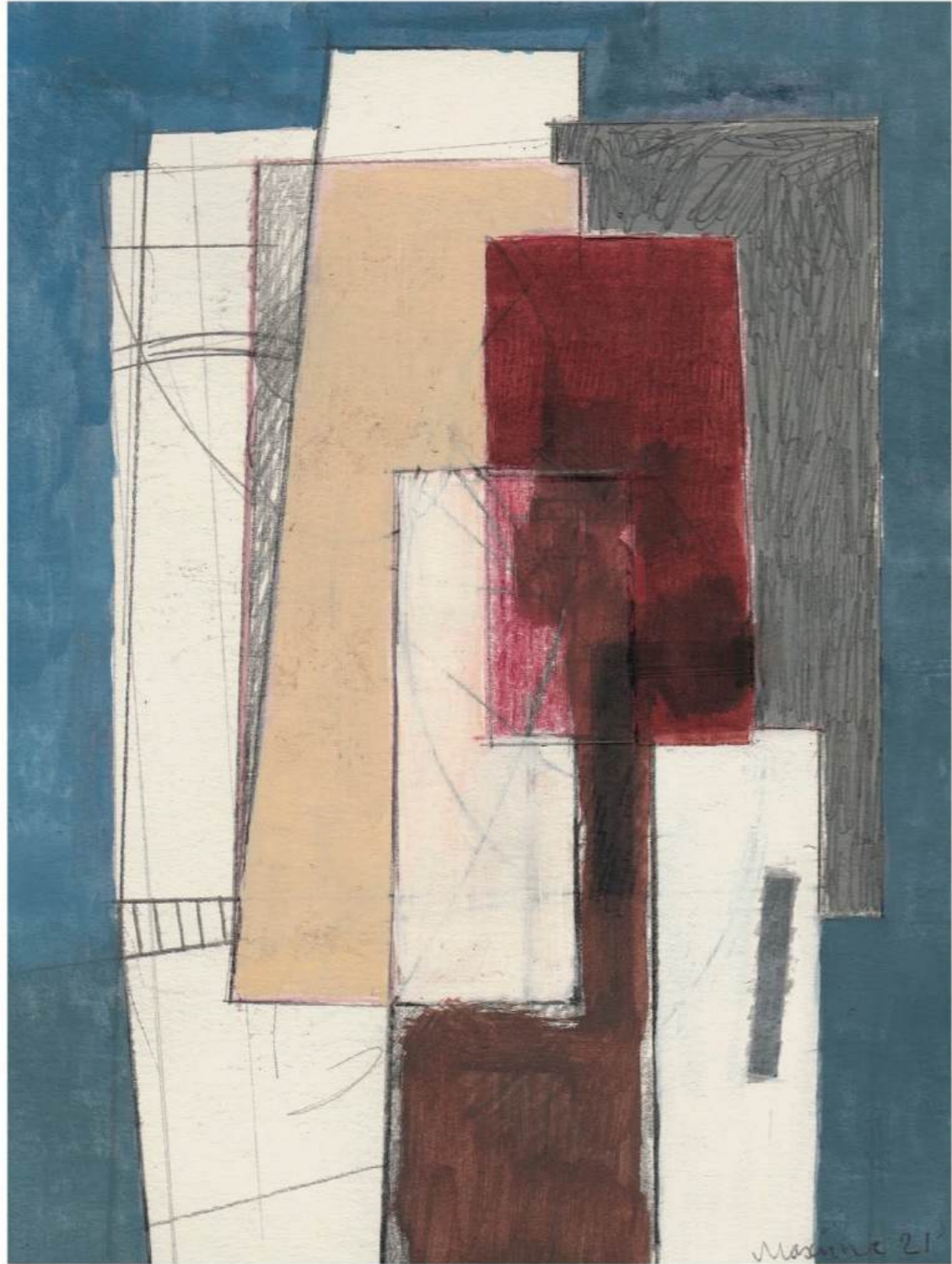

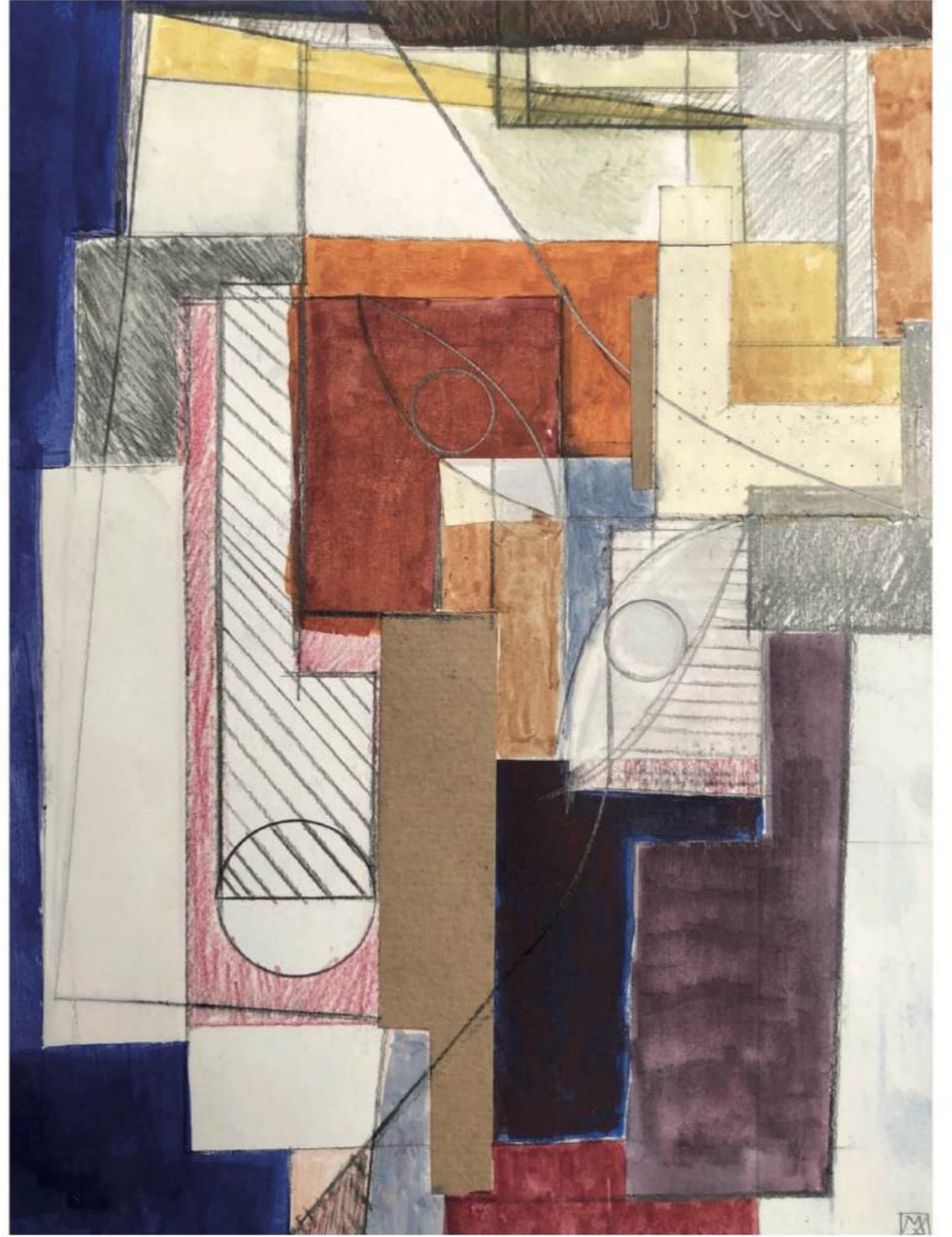
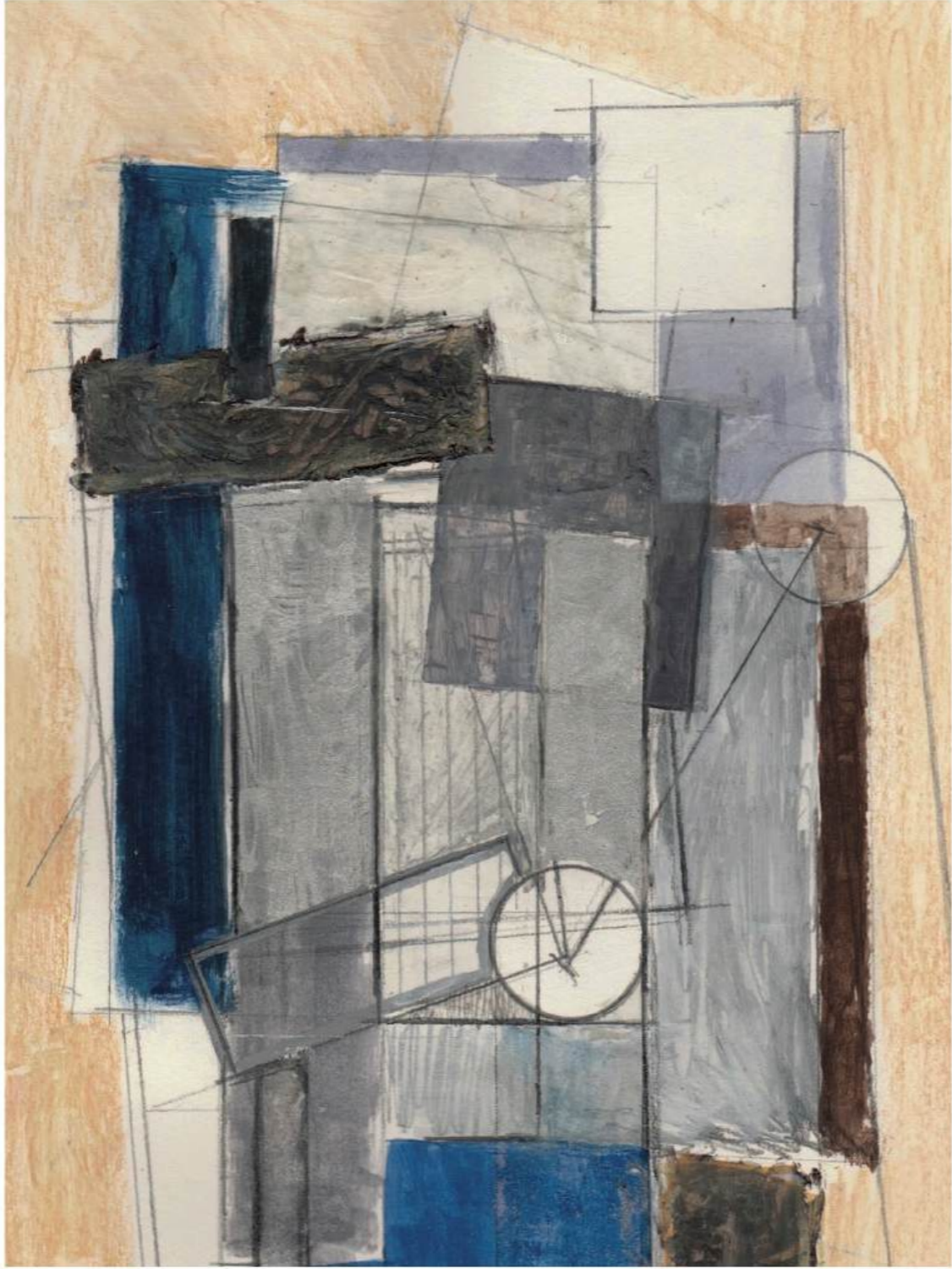



"SCULPTURAL ABSTRACTION N5"
21CM /15 CM, MIXED MEDIA ON PAPER
LONDON, 2024



"SCULPTURAL ABSTRACTION N6"
21CM /15 CM, MIXED MEDIA ON PAPER
LONDON, 2024

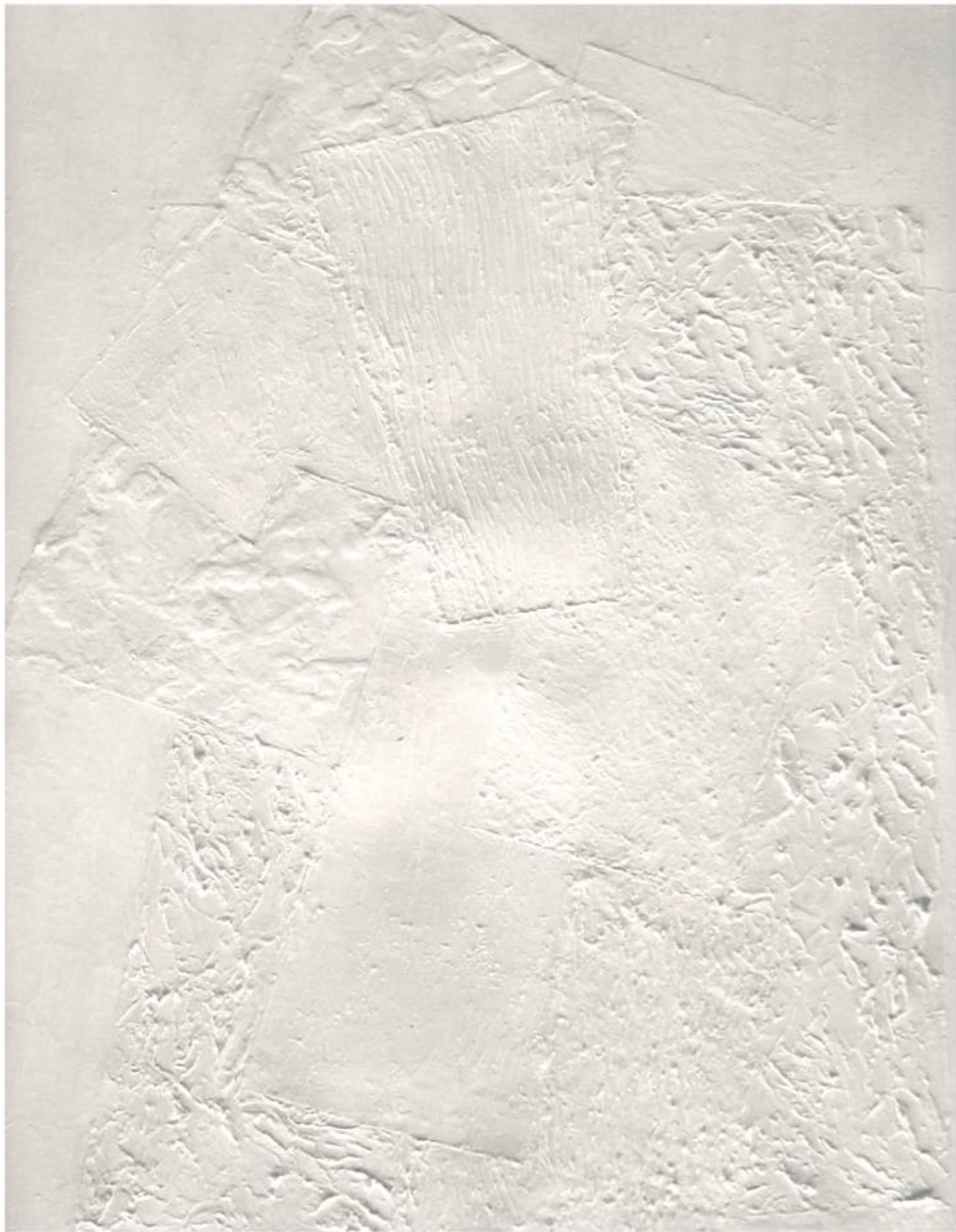

"WHITE ON WHITE N4"
21CM /15 CM, ACRYLIC ON PAPER
LONDON, 2024

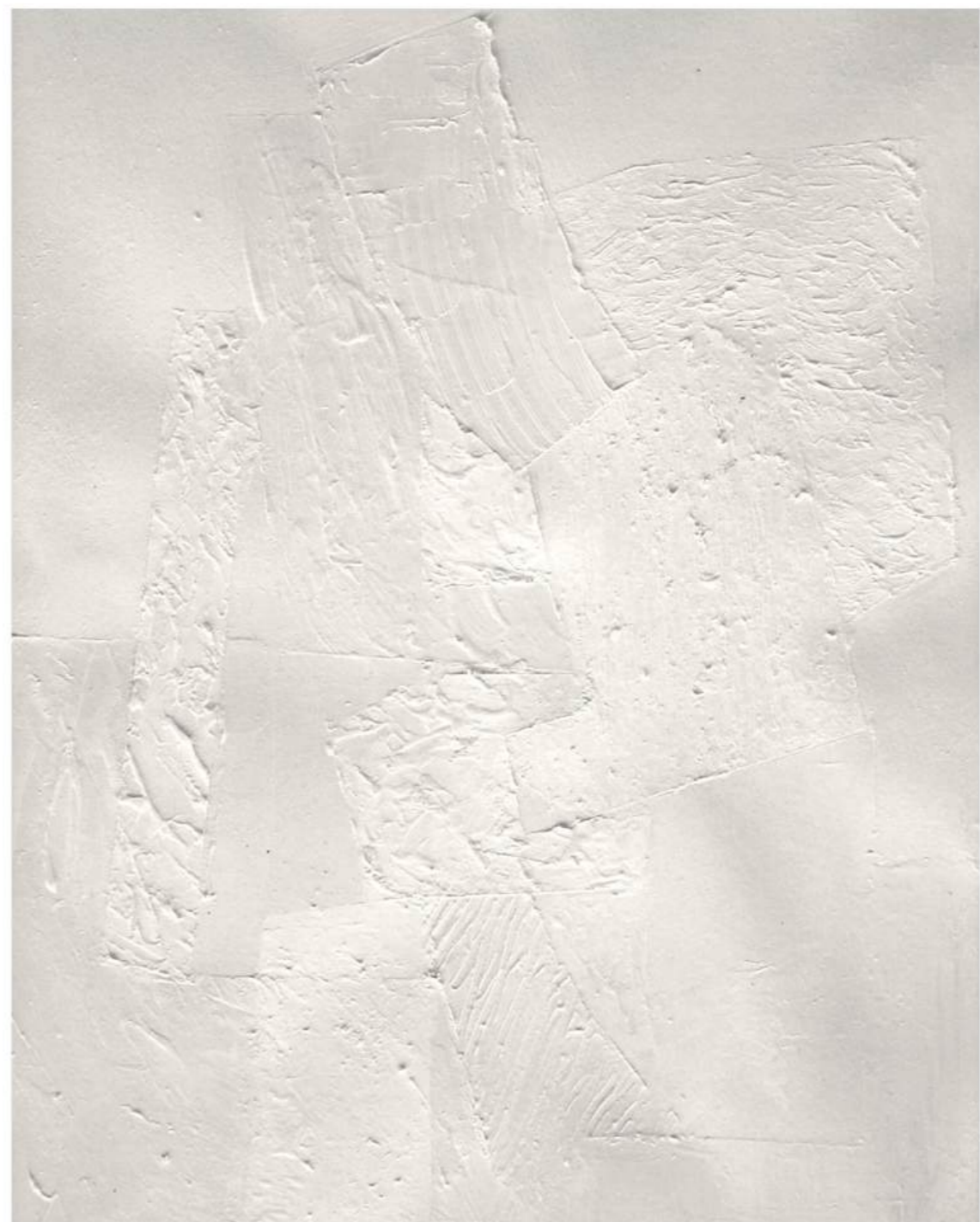

"WHITE ON WHITE N6"
21CM /15 CM, ACRYLIC ON PAPER
LONDON, 2024

A SHORT BIOGRAPHY

Max Ostroverhy was born into a family of artists, where his passion for art flourished from an early age. Attending a Steiner Waldorf school, he developed skills in drawing, painting, ceramics, and woodwork. At just 15, Max held his first solo exhibition in Paris, marking the beginning of his artistic journey.

While pursuing an MEng in Engineering and Architecture at UCL, Max explored the intersection of art and science, creating his first geometric abstractions and designing scientific devices that combined digital software with metal craftsmanship.

Fluent in French, Russian, English, and German, Max is also passionate about cross-country running and bouldering. He currently works as a design manager and plans to take a gap year to focus on his first solo painting exhibition in London.



MAX OSTROVERHY
LONDON CITY

